



## Product Specification

<b>Model Name</b>	LM116NWU02NS
<b>Description</b>	Standard LCD Module 11.6" WUXGA 1920x(RGB)x1080 Dots
<b>Date</b>	2018/09/18
<b>Version</b>	1.0

- Preliminary Specification
- Final Product Specification

Prepared by	Checked by	Approved by
SXY 2018/09/18	SXY 2018/09/18	LX 2018/09/18

### For Customer Approval

Approved By	Comment



# 深圳市美显实业有限公司 LCD Mall Limited

## Table of Contents

1. Record of Revision .....	3
2. General Specifications .....	4
3. Input/OutputTerminals.....	5
4. Absolute Maximum Rating .....	6
5. Electrical Characteristics .....	6
6. Interface Timing .....	8
7. Optical Characteristics .....	11
8. Environmental / Reliability Tests.....	14
9. Mechanical Drawing .....	15
10. Packing.....	16
11. TFT-LCD Module Inspection Criteria .....	17
12. Precautions for Use of LCD modules.....	22





## 2. General Specifications

	Feature	Spec
Characteristics	Size	11.6 inch
	Resolution	1920(horizontal)*1080(Vertical)
	Interface	EDP
	Pixel pitch (mm)	0.1335*0.1335
	Display color	Normally Black
	LCD Driver IC	TBD
	CTP Driver IC	TBD
	Viewing Direction	ALL
Mechanical	LCM (W x H x D) (mm)	263.40*157.22*2.80
	Active Area(mm)	256.32*144.18
	With /Without TSP	Without TSP
	Weight (g)	TBD
	LED Numbers	40 LEDs

Note 1: Requirements on Environmental Protection: RoHs

Note 2: LCM weight tolerance: +/- 5%



### 3. Input/Output Terminals

#### LCD PIN-MAP

No.	Symbol	Description
1	NC	No connect
2	H-GND	High Speed Ground
3	LANEI-N	Complement Signal Link Lane 1
4	LANEI-P	True Signal Link Lane 1
5	H-GND	High Speed Ground
6	LAENO-N	Complement Signal Link Lane 0
7	LAENO-P	True Signal Link Lane 0
8	H-GND	High Speed Ground
9	AUX-CH-N	True Signal Auxiliary Channel
10	AUX-CH-P	Complement Signal Auxiliary Channel
11	H-GND	High Speed Ground
12	LCD-VDD	LCD logic and driver power(3.3V)
13	LCD-VDD	LCD logic and driver power(3.3V)
14	NC	No connect
15	LCD-GND	LCD logic and driver ground
16	LCD-GND	LCD logic and driver ground
17	HPD	HPD signal pin
18	BL-GND	Backlight ground
19	BL-GND	Backlight ground
20	BL-GND	Backlight ground
21	BL-GND	Backlight ground
22	BL-ENABLE	Backlight ON/OFF
23	BL-PWM-DIM	System PWM
24	NC	No connect
25	NC	No connect
26	BL-PWR	Backlight power
27	BL-PWR	Backlight power
28	BL-PWR	Backlight power
29	BL-PWR	Backlight power
30	NC	No connect

#### 4. Absolute Maximum Rating

Item	Symbol	MIN	MAX	Unit
Supply voltage for analog	LCD-VDD	-0.3	4	V
Supply voltage for logic	LCD-VDD	-0.5	4	V
Supply current (One LED)	I <sub>LED</sub>		30	mA
Operating temperature	T <sub>OP</sub>	-10	+60	°C
Storage temperature	T <sub>ST</sub>	-20	+70	°C

Note: The absolute maximum rating values of this product are not allowed to be exceeded at any times. Should a module be used with any of the absolute maximum ratings exceeded, the characteristics of the module may not be recovered, or in an extreme case, the module may be permanently destroyed

#### 5. Electrical Characteristics

##### 5.1 Input Power

Item	Symbol	Min	Typ	Max	Unit	Applicable terminal
Supply Voltage for Analog	LCD-VDD	3.0	3.3	3.6	V	
Supply Voltage for Logic	LCD-VDD	3.0	3.3	3.6	V	
Input leakage Current	I <sub>LKG</sub>	-			μA	
Input Voltage	V <sub>I</sub>	-0.3	-	1.5	uA	

##### 5.2 Backlight Driving Conditions

Item	Symbol	Value			Unit	Remark
		Min	Typ	Max		
Voltage for LED Backlight	V <sub>F</sub>	21.6	26	27.2	V	I <sub>L</sub> =100mA
Current for LED Backlight	I <sub>L</sub>		100		mA	
Brightness Control frequency		200		2000	HZ	
ADJ input voltage	V <sub>IH</sub>	3.0		3.3	V	
ADJ input voltage	V <sub>IL</sub>	0		0.3	V	
Duty ratio		10		100	%	
Power Consumption	P		2.6		W	
LED Life Time		30000			Hr	Note

Note: Brightness to be decreased to 50% of the initial value at ambient temperature TA=25°C

### 5.3 Block Diagram

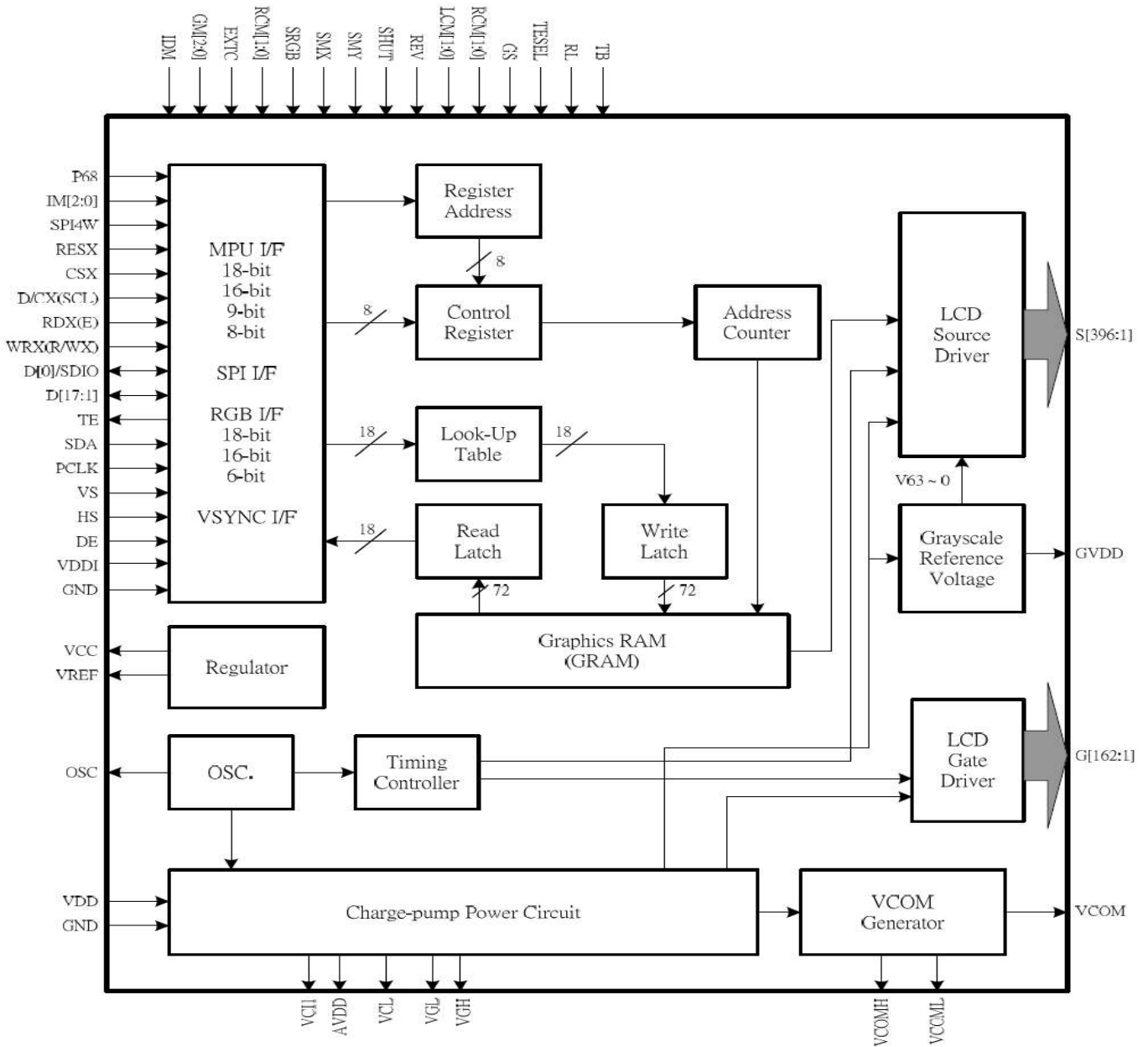

## 6. Interface Timing

### 6.1 DC Characteristics for Panel Driving

Item	Symbol	Condition	Min.	Typ.	Max.	Unit	Note
<b>Power &amp; Operation Voltage</b>							
Analog operating voltage	VCI	-	2.5	2.8	3.3	V	
Logic operating voltage	IOVCC	-	1.65	1.8	3.3	V	Note 1, 2
OTP Supply voltage	DDVDH	-	-	7	-	V	Note 1
Logic High level input voltage	VIH	-	0.7*IOVCC		IOVCC	V	Note 1
Logic Low level input voltage	VIL	-	-0.3		0.3*IOVCC	V	Note 1
Logic High level output voltage TE, SDO (SDA), CABC_PWM_OUT	VOH	IOH = -1.0mA	0.8*IOVCC		IOVCC	V	Note 1
Logic Low level output voltage TE, SDO (SDA), CABC_PWM_OUT	VOL	IOL = +1.0mA	0		0.2*IOVCC	V	Note 1
Gate Driver High Voltage	VGH	-	10.0	-	20	V	
Gate Driver Low Voltage	VGL	-	-15.0	-	-6.0	V	
Driver Supply Voltage	-	VGH-VGL	16	-	32	V	
<b>Input and Output</b>							
Logic High Level Input Voltage	VIH	-	0.7*IOVCC	-	IOVCC	V	
Logic Low Level Input Voltage	VIL	-	DGND	-	0.3*IOVCC	V	
<b>VCOM Operation</b>							
DC VCOM Amplitude Voltage	VCOM	-	-2.0	-	-0.06	V	Note 3
<b>Source Driver</b>							
Source Output Range	VSOUT	-	0.1	-	VREG1OUT-0.1	V	Note 4
Positive Gamma Reference Voltage	VREG1OUT	-	3.625	-	5.5	V	
Negative Gamma Reference Voltage	VREG2OUT	-	-5.5	-	-3.625	V	
Source Output Setting Time	Tr	Below with 99% precision	-	10	-	uS	Note 3, 4
Output Deviation Voltage (Source Output channel)	Vdev	Sout>=4.2V	-	-	20	mV	Note 3
		Sout<=0.8V	-	-	15	mV	-
Output Offset Voltage	VOFFSET	-	-	-	35	mV	Note 3
<b>Booster Operation</b>							
Booster (VCIx2) Voltage	DDVDH	-			6	V	
Booster (VCIx2) Voltage	DDVDL	-	-6			V	
Booster (VCIx2 Drop Voltage)	VCIx2 drop	loading=1mA	-	-	5	%	
Gate Driver High Voltage	VGH	-	10.0	-	20	V	
Gate Driver Low Voltage	VGL	-	-15.0	-	-6.0	V	
<b>Standby mode current consumption (Ta = 25 °C, Interface: DBI and DPI)</b>							
Sleep in mode	VCI	VCI=2.8V	-	100	-	uA	
Deep Standby mode	VCI	IOVCC=1.8V	-	1	-	uA	

#### Notes:

1. Ta = -30 to 70 °C (no damage up to 85 °C (at maximum)), IOVCC=1.65V to 3.3V, VCI=2.5V to 3.3V, DGND=0V.
2. Supply the digital IOVCC voltage equal to or less than the analog VCI voltage.
3. Source channel loading = 10KΩ,30pF/channel
4. The maximum value is between 10KΩ,30pF/channel and Gamma setting value.



### 6.2 DPI Parallel Interface (RGB Interface) Characteristics

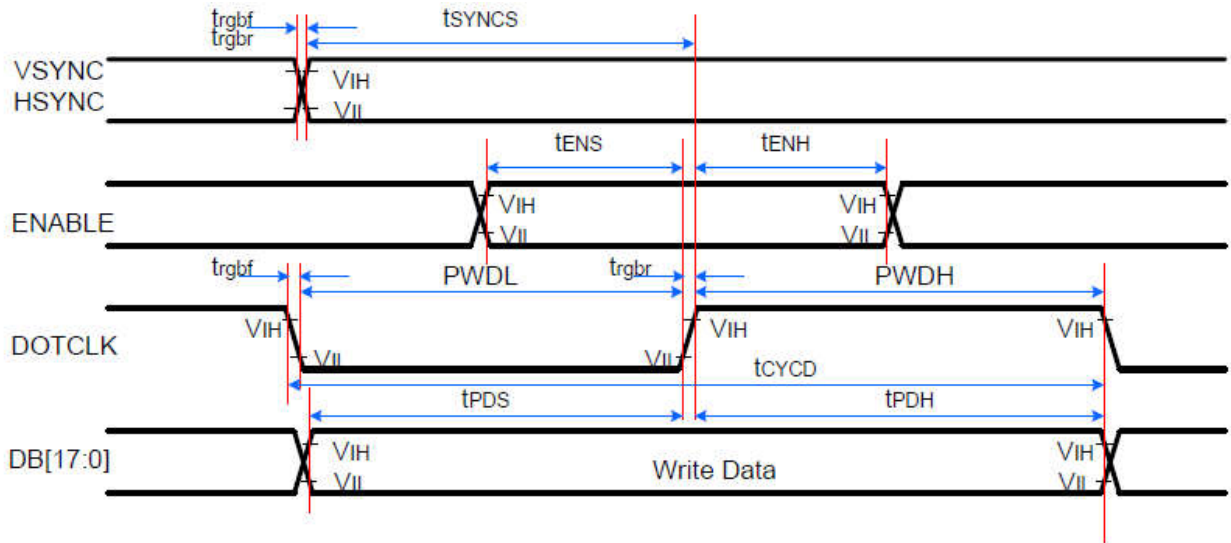

Signal	Symbol	Parameter	min	max	Unit	Description
VSYNC/ HSYNC	$t_{SYNCS}$	VSYNC/HSYNC setup time	15	-	ns	16-/18-/24-bit bus RGB interface mode
	$t_{SYNCH}$	VSYNC/HSYNC hold time	15	-	ns	
ENABLE	$t_{ENS}$	ENABLE setup time	15	-	ns	
	$t_{ENH}$	ENABLE hold time	15	-	ns	
DB [23:0]	$t_{POS}$	Data setup time	15	-	ns	
	$t_{PDH}$	Data hold time	15	-	ns	
DOTCLK	PWDH	DOTCLK high-level period	20	-	ns	
	PWDL	DOTCLK low-level period	20	-	ns	
	$t_{CYCD}$	DOTCLK cycle time	50	-	ns	
	$t_{rgbr}, t_{rgbf}$	DOTCLK,HSYNC,VSYNC rise/fall time	-	15	ns	

Note:  $T_a = -30$  to  $70$  °C,  $IOVCC = 1.65V$  to  $3.3V$ ,  $VCI = 2.5V$  to  $3.3V$ ,  $AGND = DGND = 0V$

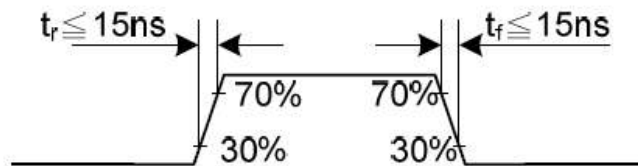

### 6.3 Capacitive touch panel Specification

The I2C is always configured in the Slave mode. The data transfer format is shown in Figure 2-4.

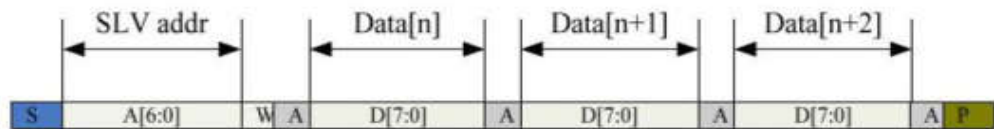
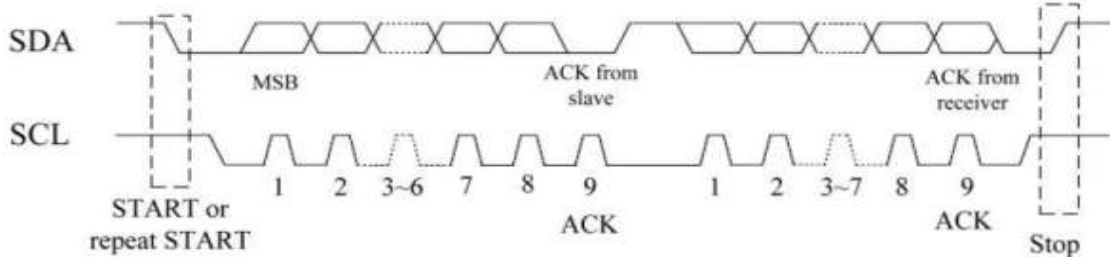

Figure 2-5 I2C master write, slave read

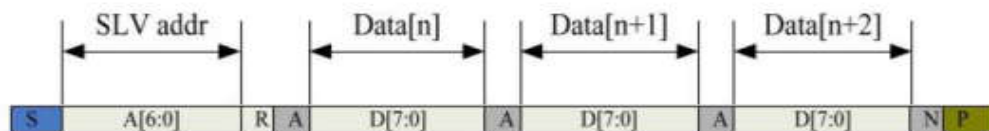

Table 2-1 lists the meanings of the mnemonics used in the above figures.

Table 2-1 Mnemonics Description

Mnemonics	Description
S	I2C Start or I2C Restart
A[6:0]	Slave address A[6:4]: 3'b011 A[3:0]: data bits are identical to those of I2CCON[7:4] register.
W	1'b0: Write
R	1'b1: Read
A(N)	ACK(NACK)
P	STOP: the indication of the end of a packet (if this bit is missing, S will indicate the end of the current packet and the beginning of the next packet)

I2C Interface Timing Characteristics is shown in Table 2-2.

Table 2-2 I2C Timing Characteristics

Parameter	Unit	Min	Max
SCL frequency	KHz	0	400
Bus free time between a STOP and START condition	us	4.7	\
Hold time (repeated) START condition	us	4.0	\
Data setup time	ns	250	\
Setup time for a repeated START condition	us	4.7	\
Setup Time for STOP condition	us	4.0	\



## 7. Optical Characteristics

ITEM	SYMBOL	CONDITIONS	SPECIFICATIONS			UNIT	NOTE
			MIN	TYP	MAX		
Luminance	L	IL=100mA	264	330	396	Cd/m <sup>2</sup>	
Contrast Ratio	CR	$\theta=0^\circ$		600			
Response Time	T <sub>ON</sub>	25°C		25	40	ms	
	T <sub>OFF</sub>						
CIE Color Coordinate	Red	X <sub>R</sub>					
		Y <sub>R</sub>					
	Green	X <sub>G</sub>					
		Y <sub>G</sub>					
	Blue	X <sub>B</sub>					
		Y <sub>B</sub>					
White	X <sub>W</sub>						
	Y <sub>W</sub>						
Viewing Angle	Hor	$\theta_{x+}$	80	89		Degree	
		$\theta_{x-}$	80	89			
	Ver	$\theta_{y+}$	80	89			
		$\theta_{y-}$	80	89			
Uniformity	Un		70	75		%	

### Note1. Definition of contrast ratio

Contrast ratio(Cr) is defined mathematically by the following formula. For more information see FIG.2.

$$\text{Contrast ratio} = \frac{\text{Luminance measured when LCD on the "White" state}}{\text{Luminance measured when LCD on the "Black" state}}$$

For contrast ratio, Surface Luminance, Luminance uniformity and CIE,the testing data is base on TOPCON's BM-5 or BM-7 photo detector or compatible.

### Note2. Definition of surface luminance.

Surface luminance is the luminance with all pixels displaying white. For more information see FIG.2.

$$L_v = \text{Average Surface Luminance with all white pixels}(P_1, P_2, P_3, \dots, P_n)$$

### Note3. Definition of luminance uniformity

The luminance uniformity in surface luminance is determined by measuring luminance at each test position 1 through n, and then dividing the maximum luminance of n points luminance by minimum luminance of n points luminance.For more information see FIG.2.

$$Y_U = \frac{\text{Minimum surface luminance with all white pixels } (P_1, P_2, P_3, \dots, P_n)}{\text{Maximum surface luminance with all white pixels } (P_1, P_2, P_3, \dots, P_n)}$$

**Note4. Definition of response time**

The response time is defined as the LCD optical switching time interval between “White” state and “Black”state. Rise time ( $T_r$ ) is the time between photo detector output intensity changed from 90% to 10%. And fall time ( $T_f$ ) is the time between photo detector output intensity changed from 10% to 90%.

For additional information see FIG1.

**Note5. Definition of color chromaticity (CIE1931)**

CIE (x,y) chromaticity, The x,y value is determined by screen active area center position P5. For more information see FIG.2.

**Note6. Definition of viewing angle**

Viewing angle is the angle at which the contrast ratio is greater than 10. Angles are determined for the horizontal or x axis and the vertical or y axis with respect to the z axis which is normal to the LCD surface. For more information see FIG.3.

For viewing angle and response time testing, the testing data is base on Autronic-Melchers’s ConoScope or DMS series Instruments or compatible.

**FIG.1. The definition of response Time**

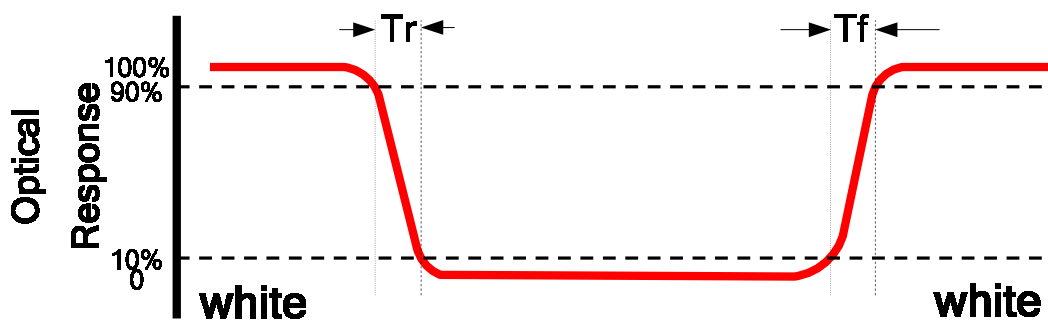

**FIG.2. Measuring method for contrast ratio, surface luminance,**

**luminance uniformity, CIE (x,y) chromaticity**

Size :  $S \leq 5''$  (see Figure a) A : 5 mm B : 5 mm

H,V : Active area

Light spot size  $\phi=5\text{mm}$  (BM-5) or  $\phi=7.7\text{mm}$  (BM-7) 50cm distance or compatible distance from the LCD surface to detector lens.

test spot position : see Figure a.

measurement instrument : TOPCON’s luminance meter BM-5 or BM-7 or compatible (see Figure c).

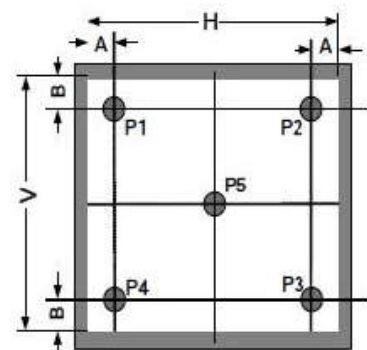

Figure a

Size : 5" <math>S \le 12.3''</math>(see Figure b) H,V : Active area

Light spot size  $\phi=5\text{mm}$ (BM-5) or  $\phi=7.7\text{mm}$  (BM-7)50cm distance or compatible distance from the LCD surface to detector lens.

test spot position : see Figure b.

measurement instrument : TOPCON's luminance meter BM-5 or BM-7 or compatible (see Figure c).

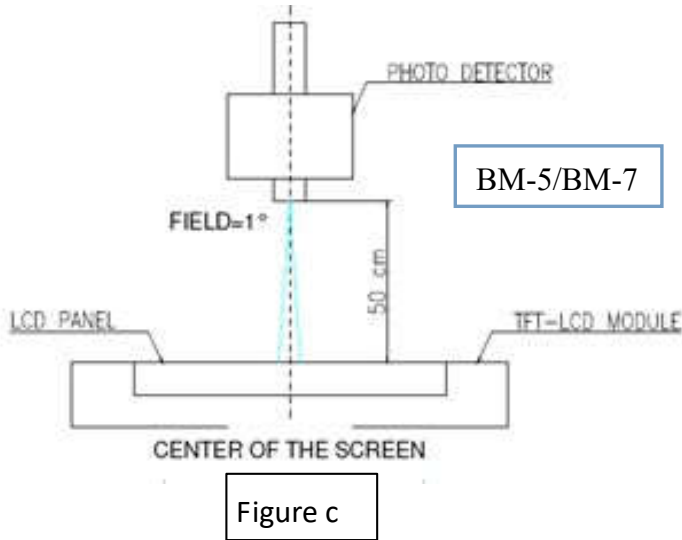
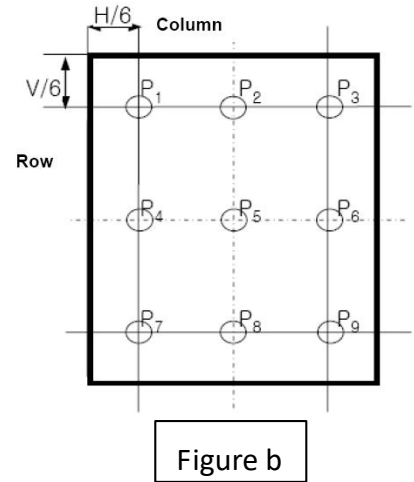
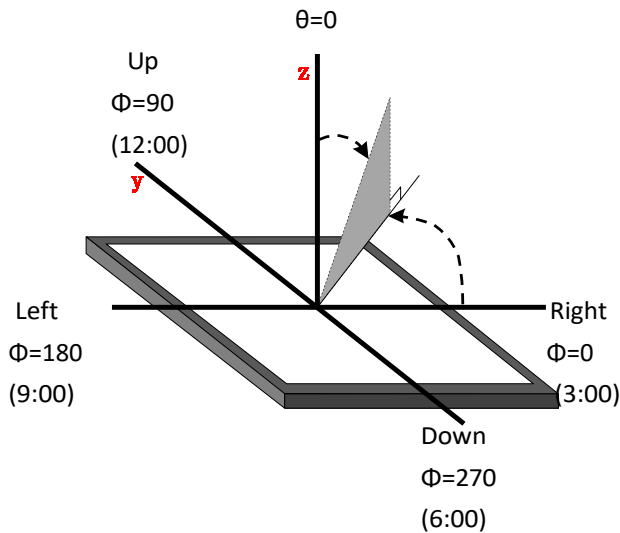

FIG.3.The definition of viewing angle



## 8. Environmental / Reliability Tests

No	Test Item	Condition	Remarks
1	High Temperature Operation	Ts= +60°C, 240hrs	Note 1 IEC60068-2-2, GB2423.2-89
2	Low Temperature Operation	Ta= -10°C, 240hrs	Note 2 IEC60068-2-1 GB2423.1-89
3	High Temperature Storage	Ta= +70°C, 240hrs	IEC60068-2-2 GB2423.2-89
4	Low Temperature Storage	Ta= -20°C, 240hrs	IEC60068-2-1 GB/T2423.1-89
5	High Temperature & Humidity Storage	Ta= +60°C, 90% RH max, 240 hours	IEC60068-2-3 GB/T2423.3-2006
6	Thermal Shock (Non-operation)	-30°C 30 min ~ +80°C 30 min Change time: 5min, 20 Cycle	Start with cold temperature, end with high temperature IEC60068-2-14, GB2423.22-87
7	Electro Static Discharge (Operation)	C=150pF, R=330 Ω, 5 points/panel Air:±8KV, 5 times; Contact: ±4KV, 5 times; (Environment: 15°C ~ 35°C, 30% ~ 60%, 86Kpa ~ 106Kpa)	IEC61000-4-2 GB/T17626.2-1998
8	Vibration (Non-operation)	Frequency range: 10~55Hz, Stroke: 1mm Sweep: 10Hz~55Hz~10Hz 2 hours for each direction of X .Y. Z. (package condition)	IEC60068-2-6 GB/T2423.5-1995
9	Shock (Non-operation)	60G 6ms, ± X, ±Y, ± Z 3 times for each direction	IEC60068-2-27 GB/T2423.5-1995
10	Package Drop Test	Height: 80 cm, 1 corner, 3 edges, 6 surfaces	IEC60068-2-32 GB/T2423.8-1995

- Note: 1. Ts is the temperature of panel's surface.  
2. Ta is the ambient temperature of sample.  
3. The size of sample is 5pcs.

## 9. Mechanical Drawing

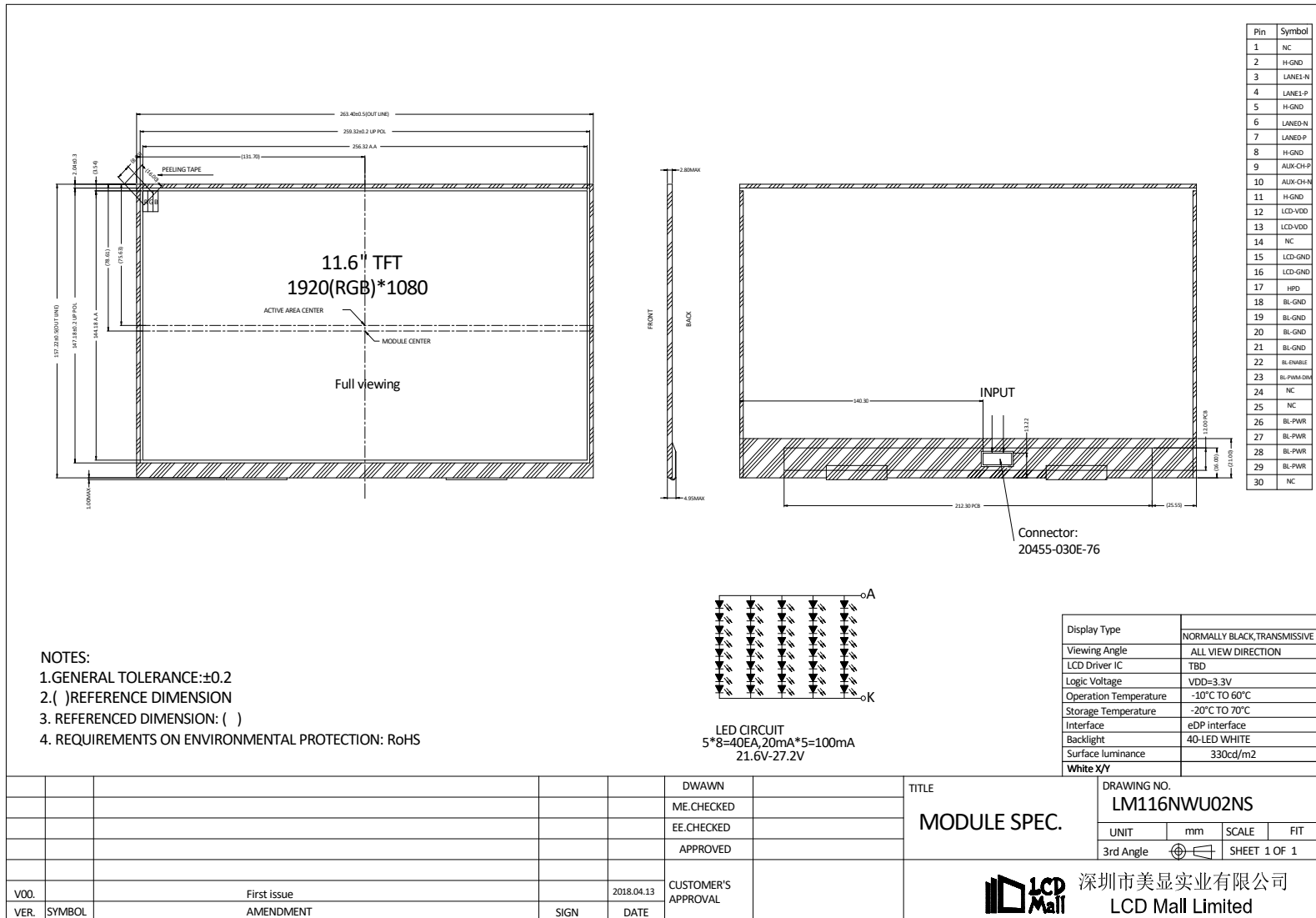

### 10. Packing

#### Packing Method

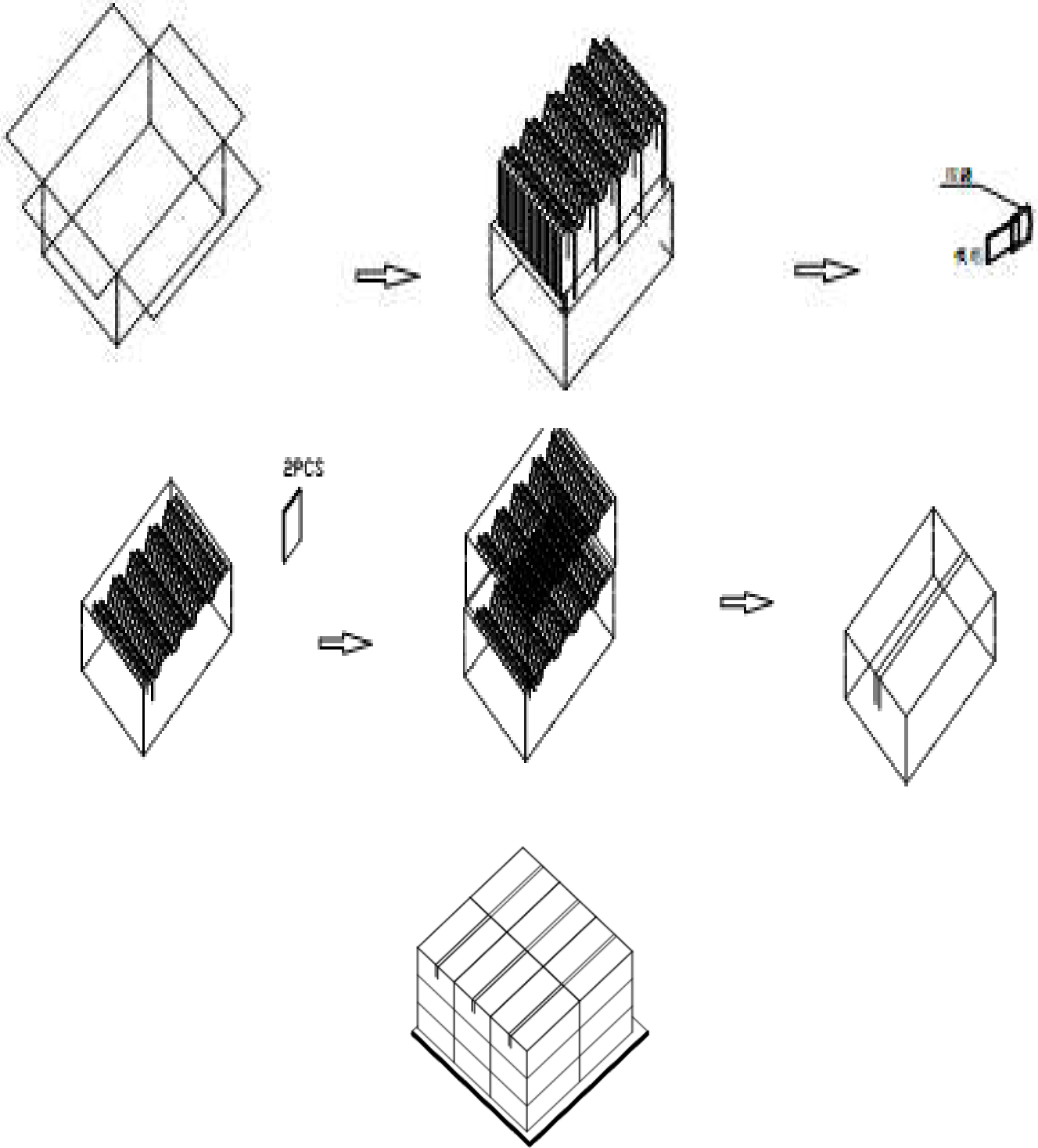



## 11. TFT-LCD Module Inspection Criteria

### 11.1 Scope

The incoming inspection standards shall be applied to TFT –LCD Modules (hereinafter Called "Modules") that supplied by LCD Mall Limited.

### 11.2 Incoming Inspection

The customer shall inspect the modules within twenty calendar days of the delivery date (the inspection period) at its own cost. The result of the inspection (acceptance or rejection) shall be recorded in writing, and a copy of this writing will be promptly sent to The seller, If the results of the inspecting from buyer does not send to the seller within twenty Calendar days of the delivery date. The modules shall be regards as acceptance.

Should the customer fail to notify the seller within the inspection period, the buyers Right to reject the modules shall be lapsed and the modules shall be deemed to have Been accepted by the buyer

### 11.3 Inspection Sampling

- 3.1. Lot size: Quantity per shipment lot per model
  - 3.2. Sampling type: Normal inspection, Single sampling
  - 3.3. Inspection level: II
  - 3.4. Sampling table: MIL-STD-105E
  - 3.5. Acceptable quality level (AQL )
- Major defect: AQL=0.65 Minor defect: AQL=1.00

### 11.4 Inspection Conditions

#### 4.1 Ambient conditions:

- a. Temperature: Room temperature  $25\pm 5^{\circ}\text{C}$
- b. Humidity:  $(60\pm 10)\% \text{RH}$
- c. Illumination: Single fluorescent lamp non-directive (300 to 700 Lux)

#### 4.2 Viewing distance

The distance between the LCD and the inspector's eyes shall be at least  $35\pm 5 \text{ cm}$ .

#### 4.3 Viewing Angle

U/D:  $45^{\circ}/45^{\circ}$ , L/R:

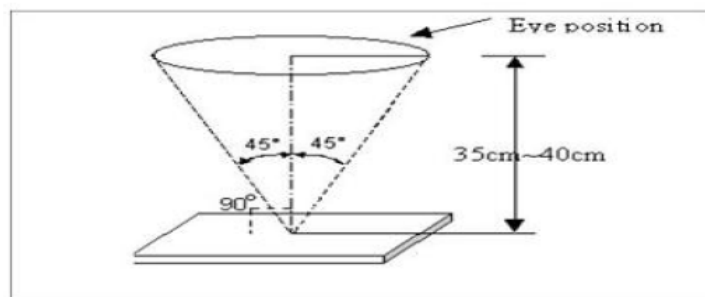

$45^{\circ}/45^{\circ}$

### 11.5 Inspection Criteria



Defects are classified as major defects and minor defects according to the degree of Defectiveness defined herein.

#### 11.5.1 Major defect

Item No	Items to be inspected	Inspection Standard
5.1.1	All functional defects	1) No display 2) Display abnormally 3) Short circuit 4) line defect
5.1.2	Missing	Missing function component
5.1.3	Crack	Glass Crack

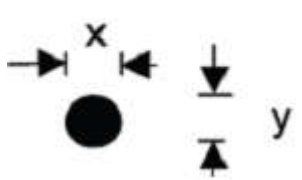
#### 11.5.2 Minor defect

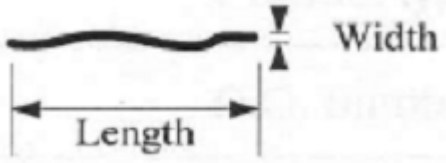
Item No	Items to be inspected	Inspection standard	
5.2.1	Spot Defect Including Black spot White spot Pinhole Foreign particle Polarizer dirt	For dark/white spot is defined $\phi = (x+y) / 2$ 	
		Size $\phi$ (mm)	Acceptable Quantity
		$\phi \leq 0.2$	Ignore
		$0.2 < \phi \leq 0.5$	3
		$0.5 < \phi$	Not allowed

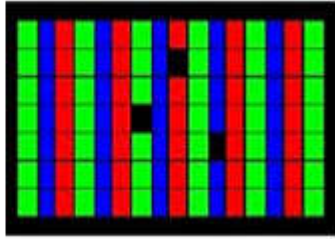
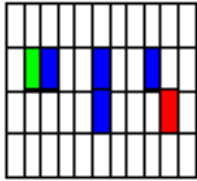
5.2.2	Line Defect Including Black line White line Scratch	Define: 		
		Width(mm) Length(mm)		Acceptable Quantity
		$W \leq 0.05$		Ignore
		$0.05 < W \leq 0.1$ $L \leq 2.5$		3
		$0.1 < W$ , or $L > 2.5$		Not allowed
5.2.3	Polarizer Dent/Bubble	Size $\phi$ (mm)		Acceptable Quantity
		$\phi \leq 0.2$		Ignore
		$0.2 < \phi \leq 0.3$		2
		$0.3 < \phi \leq 0.5$		1
		$0.5 < \phi$		Not allowed
		Total QTY		3
5.2.4	Electrical Dot Defect	Bright and Black dot define:  and 		
				
		Two Adjacent Dot		
		Inspection pattern: Full white、Full black、Red、green and blue screens		
		Item		Acceptable Quantity
		I	O	Note
Black dot defect		2		

		Bright dot defect	1	(5mm≤Distance)
		Two Adjacent Dot	1	
		There or more Adjacent Dot	Not allowed	
		Total Dot	2	
5.2.5	Glass defect	<p>1. Corner Fragment:</p>		
		Size(mm)	Acceptable Quantity	
		X≤3mm Y≤1mm Z≤T	Ignore T: Glass thickness X: Length Y: Width Z: thickness	
		<p>2. Side Fragment:</p>		
		Size(mm)	Acceptable Quantity	
		X≤5.0mm Y ≤1mm Z≤T	T: Glass thickness X: Length Y: Width Z: thickness	

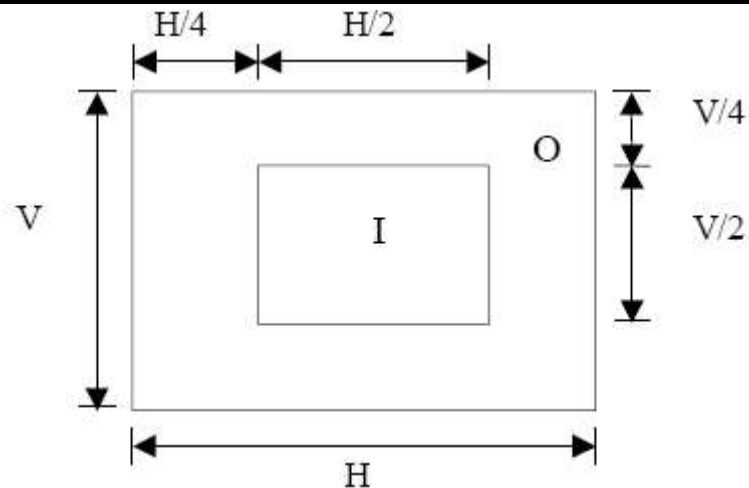



## I area & O area

- Note:
- 1). Dot defect is defined as the defective area of the dot area is larger than 50% of the dot area.
  - 2). The distance between two bright dot defects (red, green, blue, and white) should be larger than 15mm.
  - 3). The distance between black dot defects or black and bright dot defects should be more than 5mm apart.
  - 4). Polarizer bubble is defined as the bubble appears on active display area. The defect of polarizer bubble shall be ignored if the polarizer bubble appears on the outside of active display area.

### 11.6 Mechanics specification

As for the outside dimension, weight of the modules, please refer to product specification  
For more details



## 12. Precautions for Use of LCD modules

### 12.1 Handling Precautions

12.1.1. The display panel is made of glass. Do not subject it to a mechanical shock by dropping it from a high place, etc.

12.1.2. If the display panel is damaged and the liquid crystal substance inside it leaks out, be sure not to get any in your mouth, if the substance comes into contact with your skin or clothes, promptly wash it off using soap and water.

12.1.3. Do not apply excessive force to the display surface or the adjoining areas since this may cause the color tone to vary.

12.1.4. The polarizer covering the display surface of the LCD module is soft and easily scratched. Handle this polarizer carefully.

12.1.5. If the display surface is contaminated, breathe on the surface and gently wipe it with a soft dry cloth. If still not completely clear, moisten cloth with one of the following solvents:

Isopropyl alcohol & Ethyl alcohol

Solvents other than those mentioned above may damage the polarizer. Especially, do not use the following: Water & Ketene & Aromatic solvents

12.1.6. Do not attempt to disassemble the LCD Module.

12.1.7. If the logic circuit power is off, do not apply the input signals.

12.1.8. To prevent destruction of the elements by static electricity, be careful to maintain an optimum work environment.

12.1.8.1. Be sure to ground the body when handling the LCD Modules.

12.1.8.2. Tools required for assembly, such as soldering irons, must be properly ground.

12.1.8.3. To reduce the amount of static electricity generated, do not conduct assembly and other work under dry conditions.

12.1.8.4. The LCD Module is coated with a film to protect the display surface. Be care when peeling off this protective film since static electricity may be generated.

### 12.2 Storage Precautions

12.2.1. When storing the LCD modules, avoid exposure to direct sunlight or to the light of fluorescent lamps.

12.2.2. The LCD modules should be stored under the storage temperature range. If the LCD modules will be stored for a long time, the recommend condition is:

Temperature : 0°C ~ 40°C Relatively humidity: ≤80%

12.2.3. The LCD modules should be stored in the room without acid, alkali and harmful gas.

### 12.3 Transportation Precautions

The LCD modules should be no falling and violent shocking during transportation, and also should avoid excessive press, water, damp and sunshine.